

SPALDING®

**Wall-Braced Backstop
Side Fold
302-600 Series**

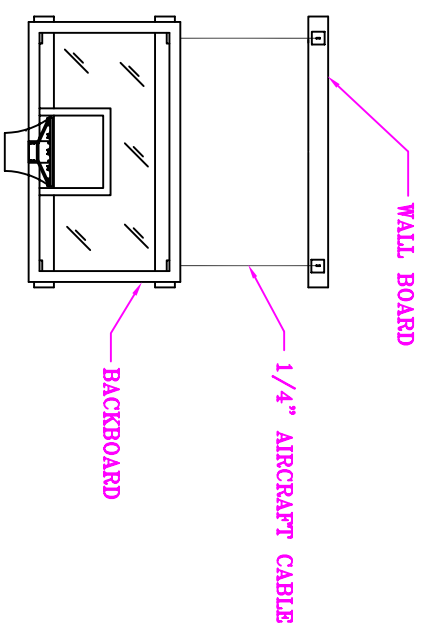
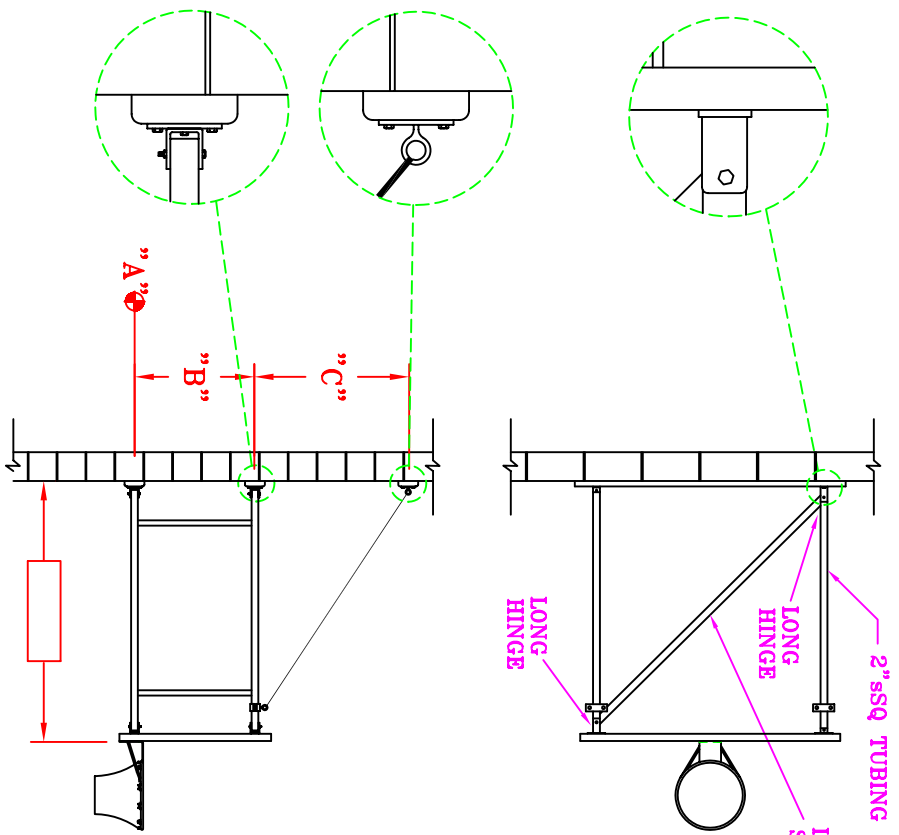

EXTENSION LENGTH (WALL TO FACE OF BACKBOARD)	DIMENSION "C"
4'-0"	3'-0" ± 6"
6'-0"	5'-0" ± 6"
8'-0"	7'-0" ± 6"
10'-0"	9'-0" ± 6"
12'-0"	11'-0" ± 6"

BACKBOARD	DIMENSION "B"	DIMENSION "A" TO FINISHED FLOOR
FAN	20"	10'-2" ± 1/4"
RECT (3-1/2' X 6')	36" ± 1/2"	9'-9" ± 1/2"
RECT (4' X 6')	42" ± 1/2"	9'-3" ± 1/2"

NOTE: EXACT MOUNTING HEIGHTS WILL BE PROVIDED ON INSTALLATION DRAWINGS SENT WITH ORDER. THIS CHART HAS BEEN DESIGNED ONLY TO PROVIDE APPROXIMATE DIMENSIONS FOR ATTACHMENT OF WALL BOARDS, SO THAT THE CUSTOMER MAY DETERMINE IF THERE IS SUFFICIENT WALL HEIGHT AND WHERE ADDITIONAL WALL SUPPORT MAY NEED TO BE PROVIDED.

SPALDING®

SF01 WALL-BRACED SIDE FOLD

DO NOT SCALE

SCG 0302612

SPALDING SPECIFICATIONS

DATE: 01/01/06

MODEL NUMBER: 302600 Series

DESCRIPTION: Wall-Braced Backstop – Side Fold

SPECIFICATIONS:

The Wall-Braced Side Fold Backstops shall have four (4) 2" SQ. structural steel tubing extensions. The tubing shall be braced, when necessary, with precision cut 2" SQ. structural steel tubing braces.

The extensions shall end at fabricated steel offset hinges to allow flat folding. The hinges shall mount to 2" x 6" No.2 Danish oiled wallboards. The hinges shall be mounted to the wood wallboards with hardware such that the wood will not be counter-bored. An attachment system that requires the wood to be counter-bored will not be approved as equal.

Tubing extensions shall be supported by ¼" aircraft cable extending diagonally from the wall to the upper extension pipes. The cable shall be attached to the extension pipes (saddle eyebolt weldment) using two cable clamps per attachment. The use of eyebolts and/or turnbuckles shall not be approved as equal.

Diagonally across the lower extension pipes there shall be a telescoping diagonal brace/locking unit which shall hold the backstop in the playing or folded position. The diagonal locking mechanism shall be easily operated from the floor by means of a factory furnished hand crank.

Tubing extensions and components shall be factory finished with an electrostatically applied powder coat finish with custom colors available.

Reference Model (WB01, 5' Extension
Showing Coordinate System,
Reaction Forces, &
Reaction Moments

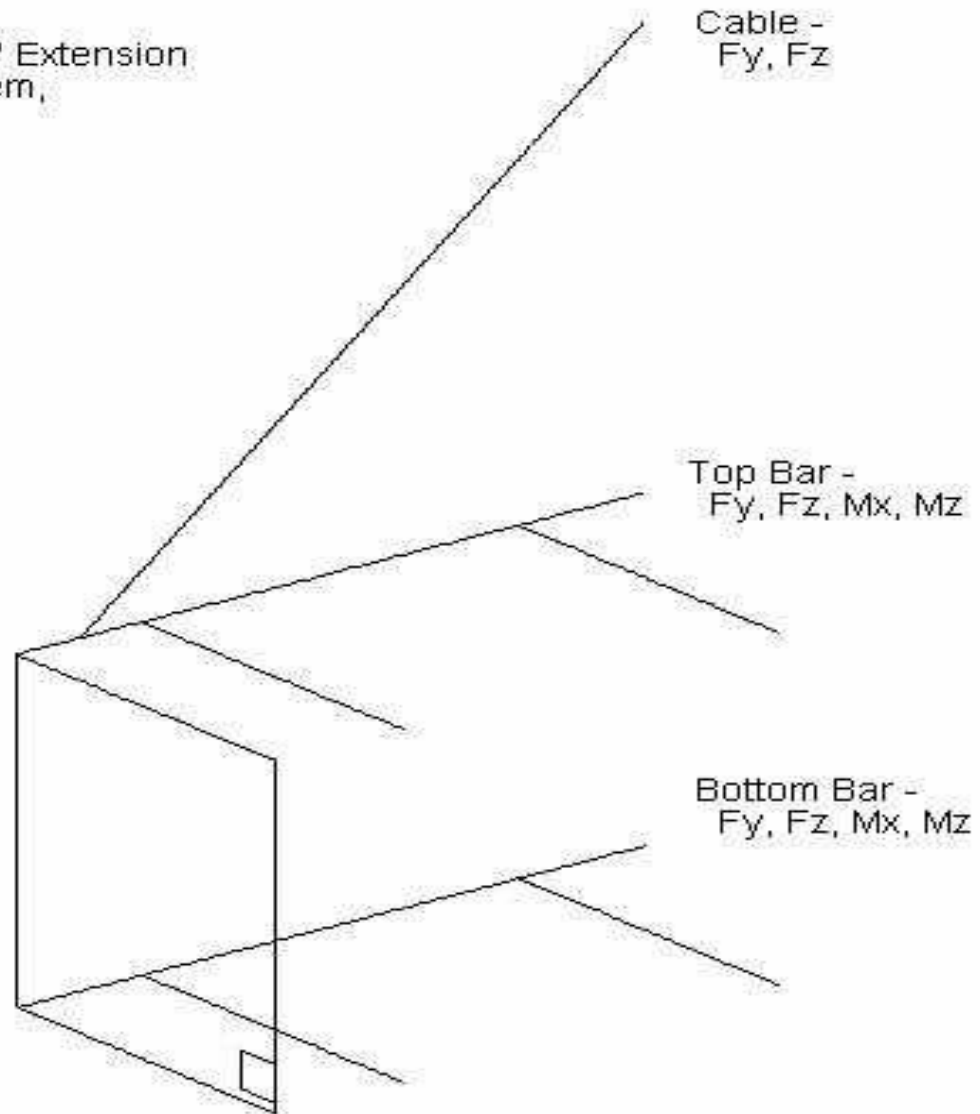
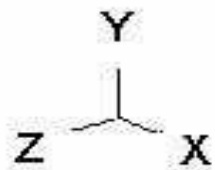

Wall Connection Reaction Moments for Wall-Braced Stationary Backboard Support Systems

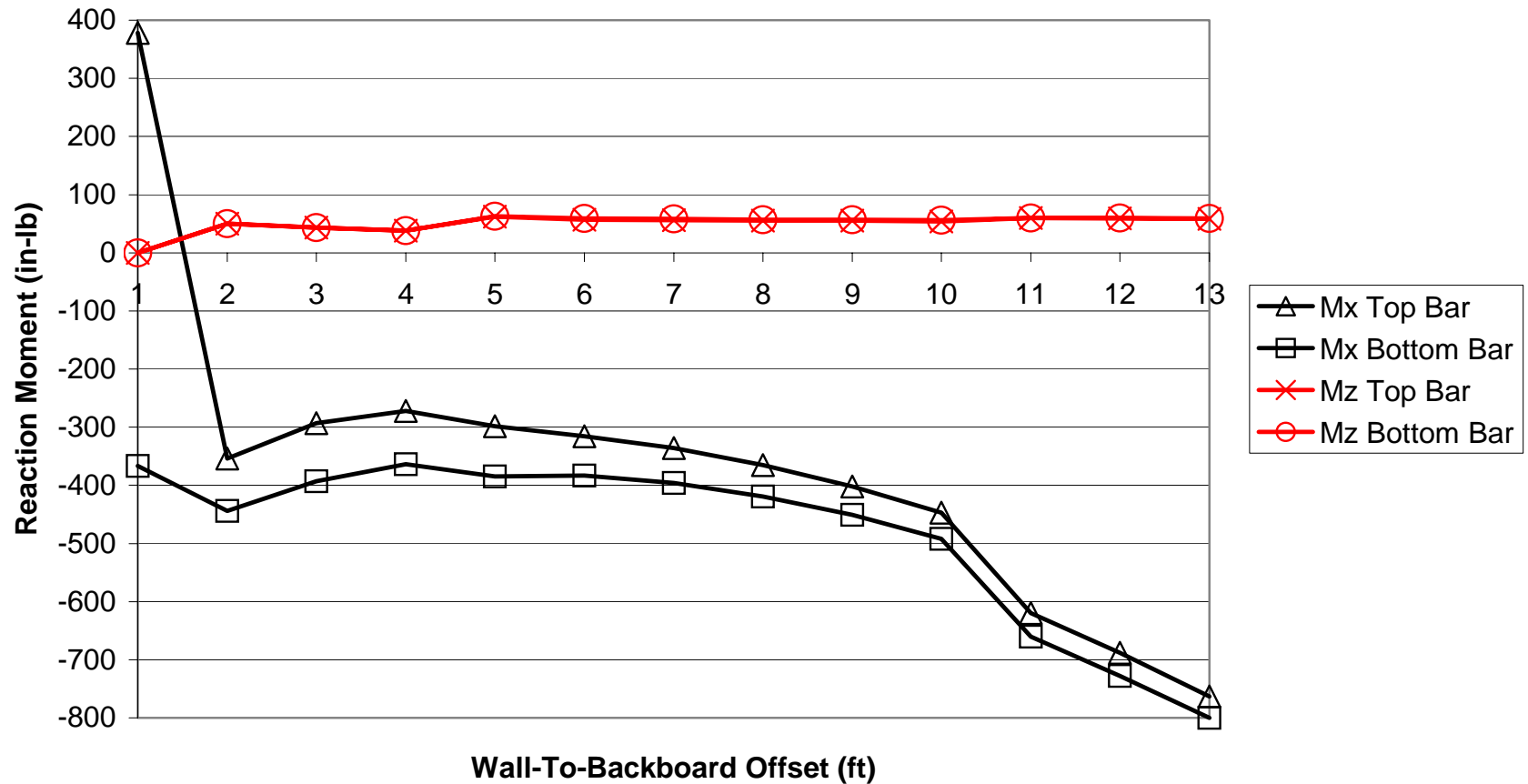

Cable & Wall Connection Reaction Loads for Wall-Braced Stationary Backboard Support Systems

